

SABA-Tool can body calibration tools for VEAW-K

The SABA-Tool can body calibration crown is the result of many years of tool engineering experience.

SABA-Tool VEAW calibration tools are available for $\text{Ø}99\text{-}330\text{mm}$ & $\text{Ø}86$, suitable for VEAW 25, VEAW-K 50/60, VEAW-K 100/120

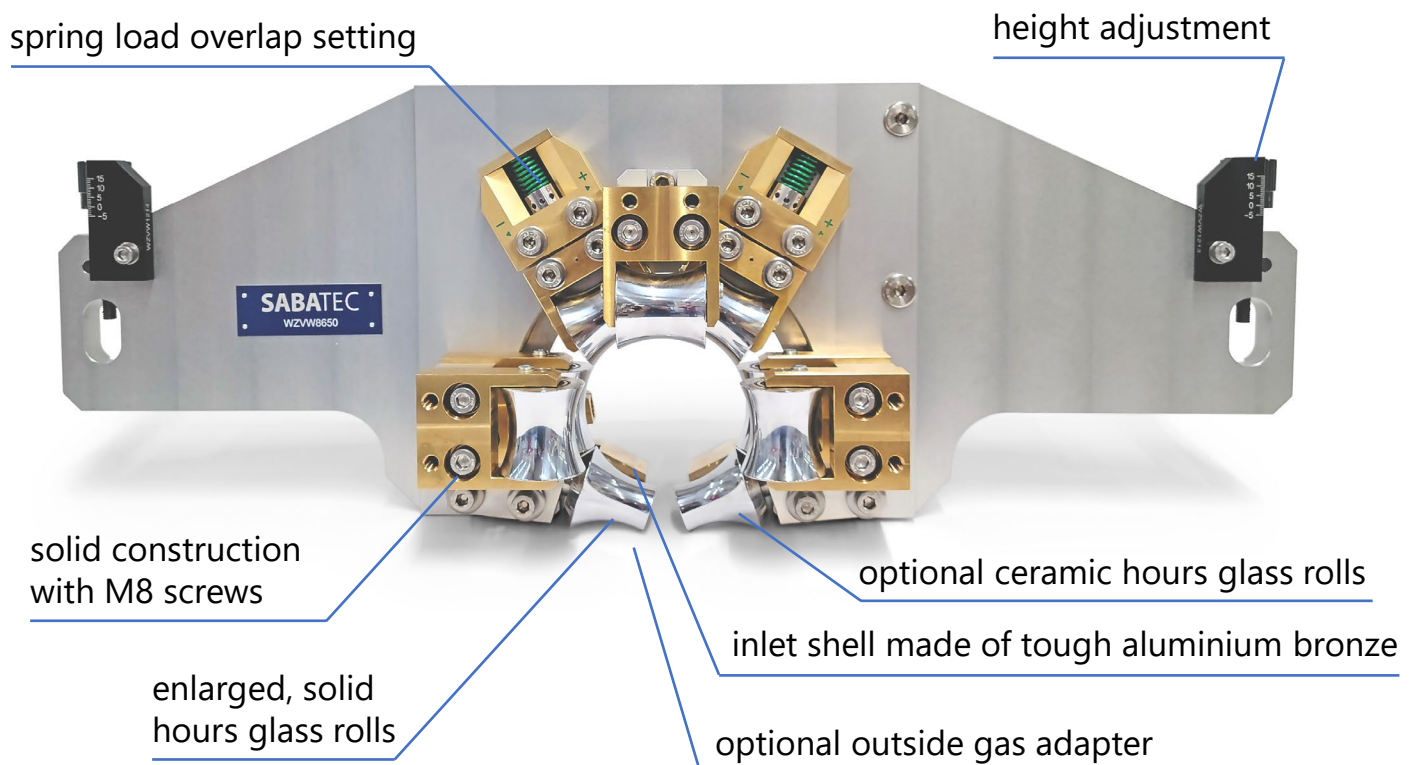

Split-Tool can body calibration tools for VEAW-K

Optional, VEAW-K calibration crowns can be ordered as split tools. This allows easy installation and removal without having to remove powder lines or hydraulics from subsequent lines. The fastening of both tool halves ensures precise reproducibility.



Roller guide tool for VEAW-K

The SABATEC roller guide tool offers several advantages compared to the original rod guide tool. It is fully equipped with durable ceramic rolls. This means less friction and therefore less marks on your can bodies. Fully insulated guide rails, made of tough aluminium bronze are mounted on top and lead the blanks to the calibration crown.

SABA-Tool VEAW roller guide tools are available for $\varnothing 99$ -330mm & $\varnothing 86$, suitable for VEAW 25, VEAW-K 50/60, VEAW-K 100/120

