

Installation manual for E1FBZ4900 wheel set with toothed belts for 1st drive Gearbox

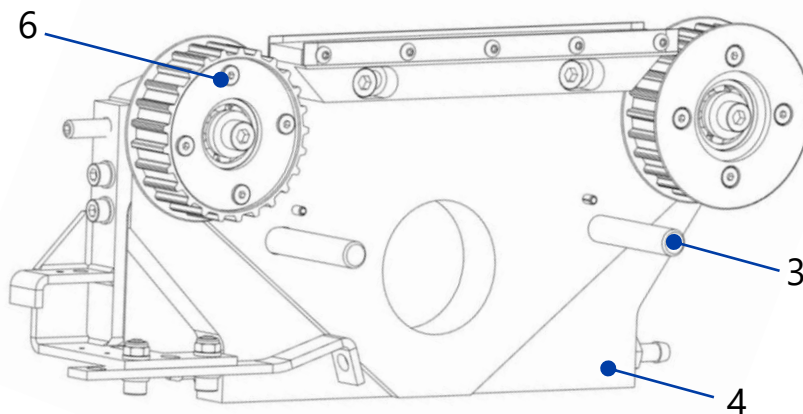

1. Remove the old clutch from the gearbox
2. Remove the old wheelset plate from the gearbox
3. Attach the new threaded bolts on the gearbox
4. Put the new wheelset plate on the threaded bolts
5. Raise the wheelset plate with the setting gauge at the desired height
6. Loosen the screws and remove the flanged wheel in front



7. Put the two setting gauges on the threaded bolts
8. Mount the E1FBZR150 clutch on the gearbox
9. Fasten the clutch with the M6 screws (3x)

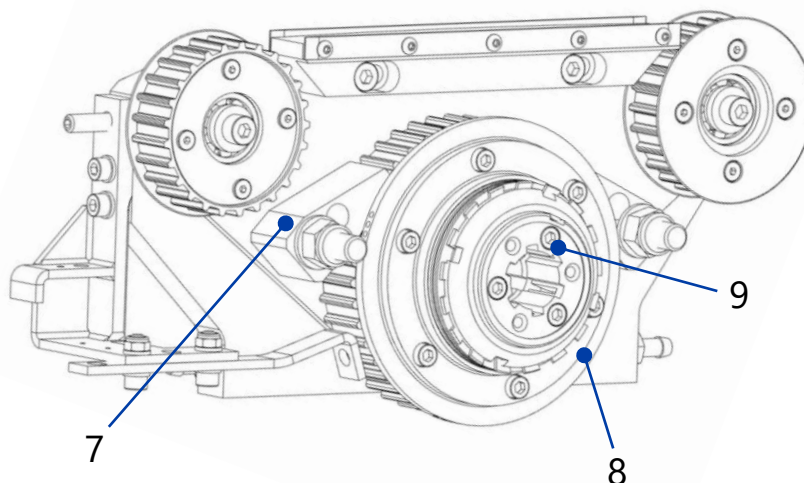

10. Attach the toothed belt to the wheelset
11. Attach the flanged wheel
12. Tighten the toothed belt with 7.3 Nm
13. Unscrew the M6 screws of the clutch (6x)
14. Repeat step 1-10 for the other side
15. Synchronize the two toothed belts
16. Tighten the M6 screws (6x) with 9.8 Nm
17. Connect the cooling to the wheelset

